



STRAINERS

Sizes: 2", 3", 4", 6", 8", 10", 12", 16", and 20"*



Strainers are designed and built for long-term, trouble-free performance in water pipeline service.

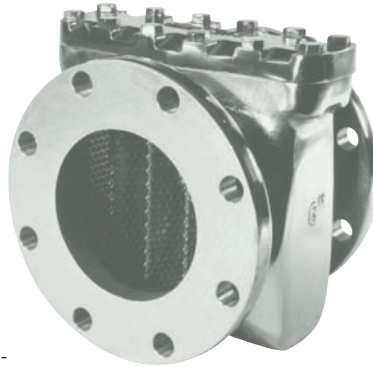

Neptune Strainers are designed and built for long-term, trouble-free performance in water pipeline service. They are specially designed for installation with Turbine or TRU/FLO® Compound meters and are compatible with all other makes as well.

Neptune recommends that a strainer be installed with each Turbine or TRU/FLO Compound meter to prevent meter damage and to ensure accurate registration regardless of the configuration of the meter installation.

When installed at the inlet of a turbine or compound meter, the strainer performs two very important functions:

- It provides protection against damage to the turbine meter measuring element from debris or foreign material in the pipeline.
- The stainless steel, plate-type strainer element is designed to improve the velocity profile of the flow stream entering the meter. This velocity profile improvement optimizes turbine meter performance. Good metering practice normally requires 8 to 10 diameters of straight pipe at the meter inlet to minimize velocity profile distortion caused by upstream valves or other fittings. The Neptune strainer reduces this long straight-run requirement and simplifies meter installation.

Neptune strainers are built of the highest quality, time-proven materials available for water pipeline service. Strainer bodies and covers in 2" through 10" sizes are no-lead high copper alloy; the 12", 16", and 20" are epoxy-coated steel. Strainer elements and cover bolts in all sizes are stainless steel.

Neptune strainers are rated at 150 psi working pressure. Each strainer is hydrostatically tested at 300 psi before shipment to ensure hydraulic integrity.

KEY FEATURES

- No-lead high copper alloy body ensures durability and corrosion resistance
- ANSI/NSF 61 certified
- Low head loss
- Stainless steel strainer plate and cover bolts
- Height to center line matches Neptune Turbines for easy installation
- In-line serviceability

**12", 16", and 20" are epoxy-coated steel*

PERFORMANCE

CONSTRUCTION

WARRANTY

Neptune provides a limited warranty with respect to its strainers for performance, materials, and workmanship.

For owner maintenance purposes, Neptune offers a complete inventory of replacement parts. When required, maintenance is easily accomplished without removing the strainer from the service line.

DIMENSIONS

Meter Size	A in/mm	B in/mm	C in/mm	D in/mm	E in/mm	F in/mm	No. of Holes	Hole Dia. in/mm	Weight lbs/kg
2"	7 178	6 152	5 1/4 133	2 1/8 54	4 1/2 114	3/4 19	2	3/4 19	16 7.3
3"	6 152	8 1/2 216	8 3/4 222	3 3/4 95	6 152	5/8 16	4	3/4 19	32 14.5
4"	7 1/2 191	9 3/4 248	10 1/2 267	4 1/2 114	7 1/2 191	11/16 17	8	3/4 19	42 19.0
6"	9 229	11 3/4 298	11 1/2 292	5 1/2 140	9 1/2 241	7/8 22	8	7/8 22	80 36.3
8"	10 254	14 356	13 1/2 343	6 3/4 171	11 3/4 298	1 1/8 29	8	7/8 22	120 54.5
10"	15 381	18 1/4 464	18 1/4 464	8 203	14 1/4 362	1 3/16 30	12	1 25	160 72.6
12"	16 7/8 429	18 7/8 479	20 1/2 521	9 1/2 241	17 432	13/16 21	12	1 25	180 81.6
16"	25 1/4 641	28 711	20 3/4 527	11 3/4 299	21 1/4 540	1 25	16	1 1/4 29	240 108.8
20"	18 5/8 473	28 711	26 1/8 664	13 3/4 349	25 635	1 1/8 29	20	1 1/4 32	300 136.0

PRESSURE LOSS

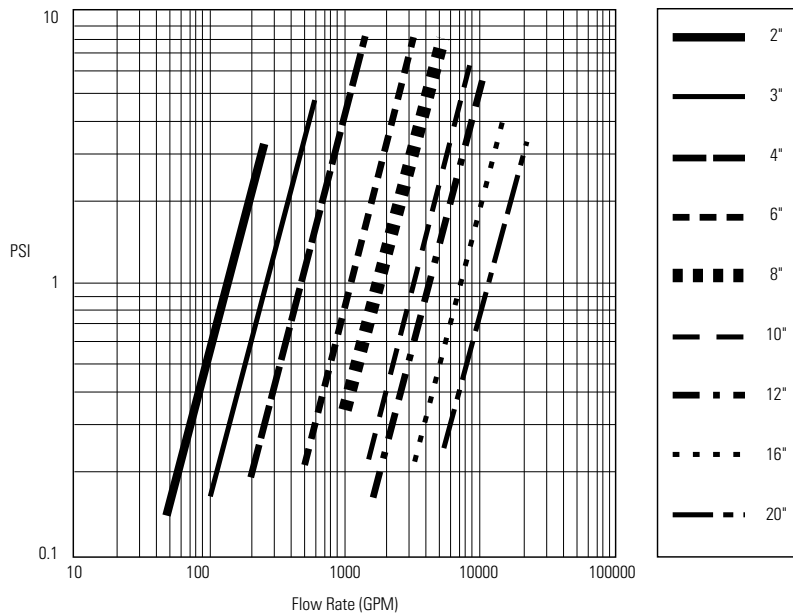

This chart shows typical meter performance. Individual results may vary.

STRAINER PARTS NUMBERS

- 2" 53120-000 No-lead high copper alloy
- 3" 53107-000 No-lead high copper alloy
- 4" 53107-100 No-lead high copper alloy
- 6" 52000-201 No-lead high copper alloy
- 8" 52000-304 No-lead high copper alloy
- 10" 52000-402 No-lead high copper alloy
- 12" 9276-000 Steel
- 16" 9276-100 Steel
- 20" 9276-200 Steel

MAXIMUM OPERATING PRESSURE

- 150 psi

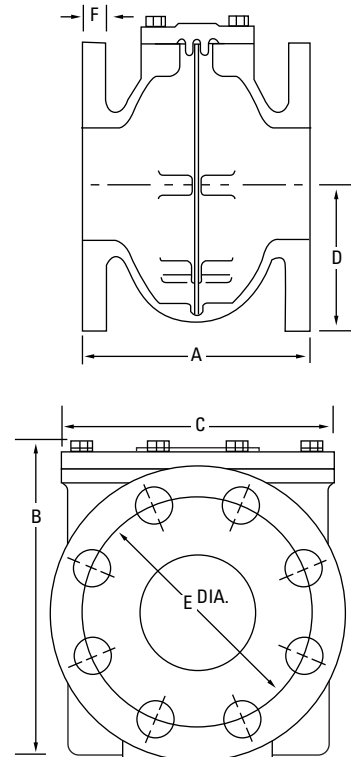

Neptune engages in ongoing research and development to improve and enhance its products. Therefore, Neptune reserves the right to change product or system specifications without notice.

Neptune Technology Group Inc.

1600 Alabama Highway 229
Tallahassee, AL 36078
USA
Tel: (800) 645-1892
Fax: (334) 283-7299

Neptune Technology Group (Canada) Ltd.

7275 West Credit Avenue
Mississauga, Ontario
L5N 5M9
Canada
Tel: (905) 858-4211
Fax: (905) 858-0428

Neptune Technology Group Inc.

Ejército Nacional No. 418
Piso 12, Desp. 1201-1202
Col. Chapultepec Morales
Delegación Miguel Hidalgo
11570 México, Distrito Federal
Tel: (525) 55203 5294 / (525) 55203 5708
Fax: (525) 55203 6503



NEPTUNE
TECHNOLOGY GROUP

neptunetg.com