



R450™ METER INTERFACE UNIT (MIU)

Daily N_SIGHT into Your Water Distribution System



R450 Meter Interface Unit (MIU)

The R450™ Meter Interface Unit (MIU) is a high-power, two-way radio frequency (RF) meter data collection device designed specifically for use with Neptune's ARB® FixedBase™ AMI System for water utilities. Designed for both wall and pit applications, the high-power RF transmission optimizes the number of collectors, thereby lowering a utility's overall deployment cost.

The R450 MIU is compatible with Neptune ARB® III, IV, V, ProRead™, E-Coder®, and Sensus ECR® II and ICE® (ECR® III).

The R450 MIU is designed to collect meter usage data and remotely transmit the information to tower-based collectors at pre-determined intervals. The R450 MIU is a powerful MIU that operates within the 450-470 MHz FCC licensed band to ensure

maximum read success rates as well as reliable RF performance. The standard R450 MIU is programmed to deliver meter usage and 24-hour consumption profile data daily. Hourly consumption profiling helps address such issues as consumption disputes and conservation compliance as well as monitoring large commercial and industrial usage.

The R450 MIU coupled with Neptune's E-Coder Solid State Absolute Encoder can monitor, identify and notify utilities of alarm states, such as continuous leaks and reverse flow occurrences. The R450 MIU can be configured to send priority alarms via email to utility personnel when key system events are identified.

KEY BENEFITS

- Non-Revenue Water Monitoring and Analysis
 - Total daily production vs. total daily consumption
 - Time-synchronized midnight meter reading for all MIUs
 - Daily household leak monitoring system
 - Improves customer service
 - Daily distribution system leak monitoring
 - Compatibility with acoustic leak sensors allows utility to identify infrastructure issues
- Improves Operational Efficiencies
 - Configurable proactive alarm notification
 - Residential: Leak, tamper, and reverse flow detection
 - Distribution: Leaks in the distribution mains
 - Optimum read success rates and security with licensed frequencies
 - R450 MIUs configurable over the air
 - Endpoints are configurable (two-way)
 - No need for truck rolls
 - Provides tools for Time-of-Use billing
 - Water conservation
 - Allows alternate billing methods
 - Real-time installation tools
 - Eliminates return service calls
- Supports Conversation Initiatives
 - Reduce Non-Revenue Water
 - Track water usage restrictions (odd/even-day usage)
 - Email consumption to the end user
- System Software Hosted or On-site
 - At-a-glance system health screen
 - Predefined management reports
 - Supports mapping for quick analysis of system issues

Dimensions: See Below
 Weight (Pit and Wall MIU): 1.0 lbs (454 grams)

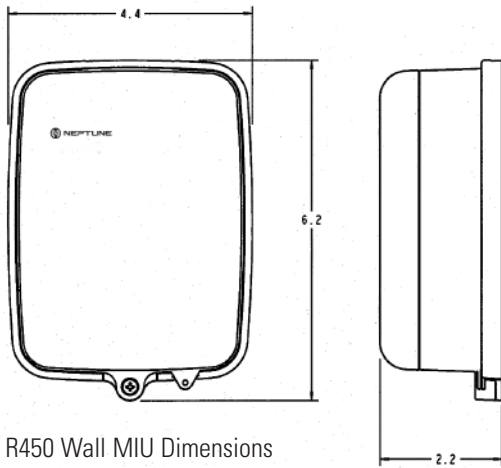

R450 Wall MIU Dimensions

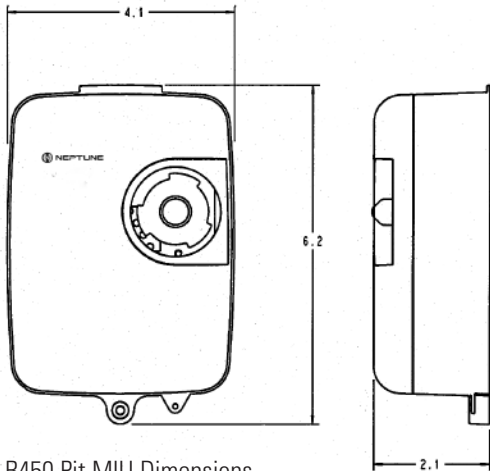

R450 Pit MIU Dimensions

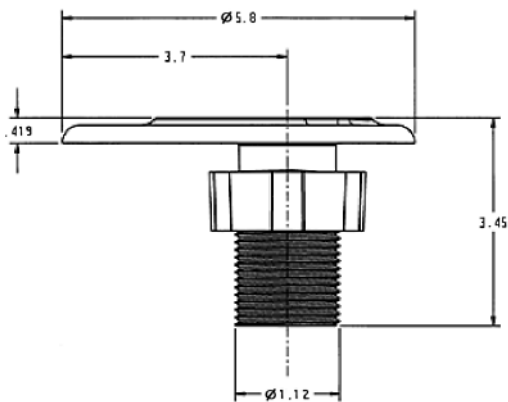

R450 Pit Antenna Dimensions

- Electrical Specifications:
 - Lithium battery with Capacitor
- Transmitter Specifications:
 - Transmit period: Standard configuration is a midnight meter reading and 24-hour usage/ consumption data – daily
 - Operational frequency: Licensed 450-470 MHz band
 - Output Power: Meets FCC Part 90
- Encoder Compatibility:
 - Compatible with Neptune encoders, Sensus ECR II & ICE encoders
- Environmental Conditions:
 - Operating temperature: -22°F to +149°F (-30°C to +65°C)
 - Storage temperature: -40°F to +158°F (-40°C to +70°C)
 - Operating humidity:
 - R450 Wall MIU – 0 to 95%, condensing
 - R450 Pit MIU – 100% submersible

Neptune engages in ongoing research and development to improve and enhance its products. Therefore, Neptune reserves the right to change product or system specifications without notice.

Neptune Technology Group Inc.

1600 Alabama Highway 229
 Tallahassee, AL 36078
 USA
 Tel: (800) 645-1892
 Fax: (334) 283-7293

Neptune Technology Group (Canada) Ltd.

7275 West Credit Avenue
 Mississauga, Ontario
 L5N 5M9
 Canada
 Tel: (905) 858-4211
 Fax: (905) 858-0428

Neptune Technology Group Inc.

Ejército Nacional No. 418
 Piso 12, Desp. 1201-1202
 Col. Chapultepec Morales
 Delegación Miguel Hidalgo
 11570 México, Distrito Federal
 Tel: (525) 55203 5294 / (525) 55203 5708
 Fax: (525) 55203 6503

